

SPECIAL BEARINGS

for the Sugar Industry

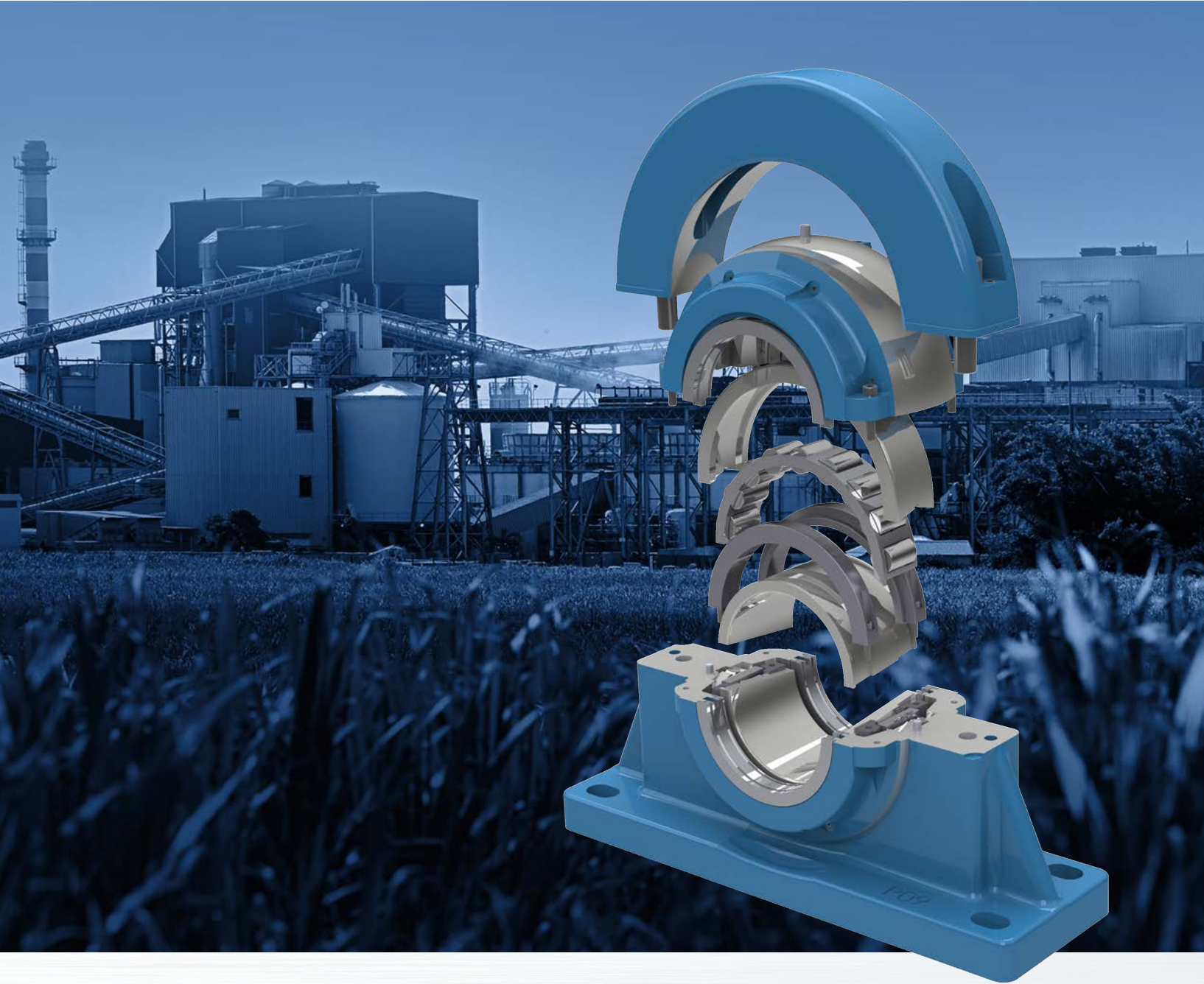

atlantic-bearing.com

*Argentina - Bolivia - Brazil - Chile - China - Colombia - Costa Rica - Dominican Republic - Ecuador
El Salvador - Guatemala - Honduras - Italy - Mexico - Nicaragua - Panama - Peru - Spain - USA*

ACB
ATLANTIC CUSTOM BEARINGS

ACB Bearings has established itself among the most recognized and trusted brands of custom bearing manufacturing for the heavy industry. Our philosophy is to offer our customers a customized solution that includes affordable pricing, quick deliveries, small-scale production, and changes to standard bearing designs for a specific customer need. Our success has been enhanced by maintaining a consistent standard of quality throughout our range of manufactured special bearings.

ACB-USA large TQO four row taper roller bearing.

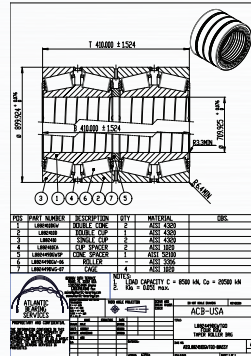
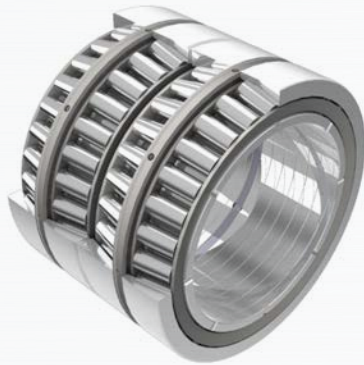

Bore diameter: 27" (685.8 mm) / Application: F0 stand hot rolling mill / All components manufactured from bearing case hardened steel.

Rollers and races with optimized profile to maximize bearing life / engineering coating in all components available under request

ACB TRB Sealed Cartridge for palletizing heat treatment cars wheels

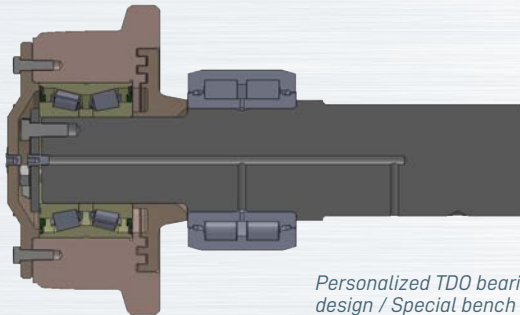

Personalized TDO bearing. 430222.XUDO Bore Ø 110 mm / Special Sealing material and design / Special bench end play to reduce mounting errors / Special Internal geometry to increase load capacities / Bering internal Grease capacity maximized to archive longer re-lub. Periods / Self-contained, pre-assembled and pre-lubricated / Reduces maintenance costs/ full reconditioning "ready" design.

FLB45/80x70/70 Flexible CRB Continuous Casting Machine Altos Hornos de Mexico (AHMSA) working from 2003

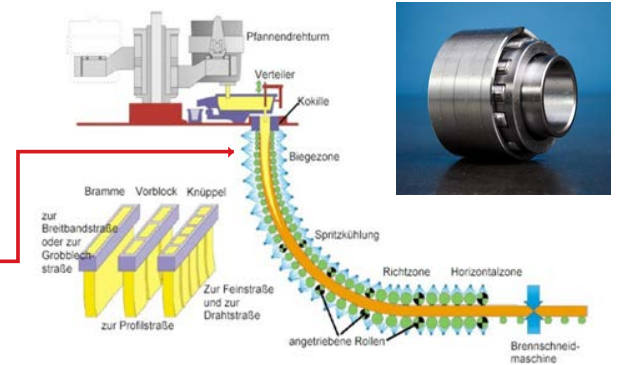
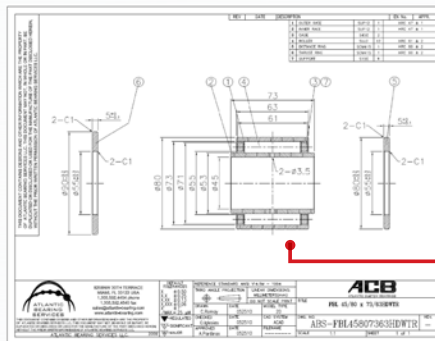

ACB triple ring cylindrical roller bearing units for 5000 HP Synchronic Electric Motor replacing plain bearings

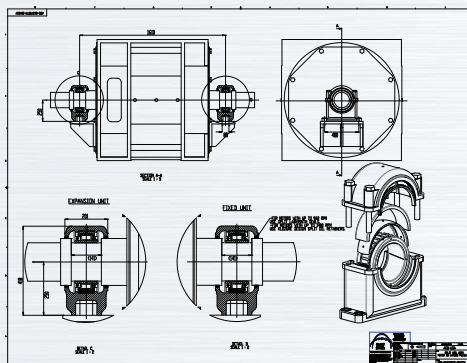

Split Triple ring CRB Bore Ø 300 mm / Rollers with optimized raceway profile / outer ring with engineering coating / special housing made of cast steel.

State of the Art Every single application is treated as a special case and analyzed with the necessary depth accordingly to provide the most customized solution. There is no limit for personalization, from internal geometry to external special coatings.

Applications One of the great advantages of working with **ACB** is our long experience in a wide variety of industries. We understand their technical and productive needs. We provide our clients with specialized professionals who will understand you from the start in order to arrive at the best solution in the shortest time possible.



Thrust Taper Roller Bearing
Siderurgica Balboa, Jerez, Spain

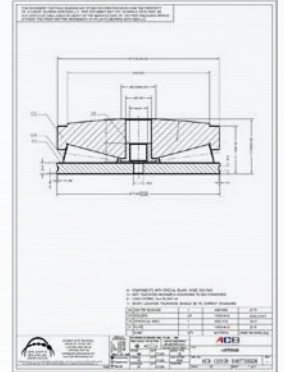
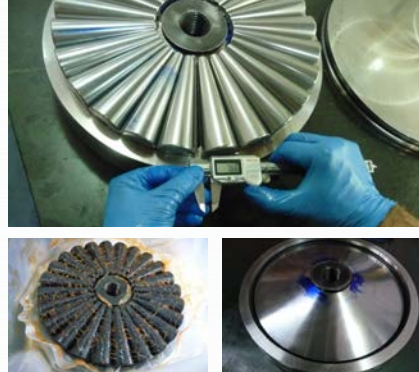

ACB full complement cylindrical roller bearing for planetary gear reducers with engineering surface coating.

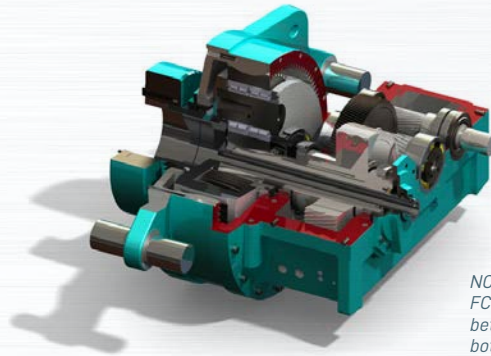

NCF/NNCF Full complement CRB WITH Engineering Coating in all components / FCCRB with the lowest friction coefficient in the market / extended bearing life due a better raceway micro geometry / special heat treatment on both races bring to our bearing high impact resistance capability and less sensitive to the cracks propagations.

ACB large three row cylindrical roller Slewing Ring bearing

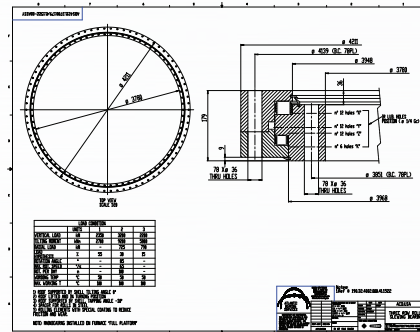
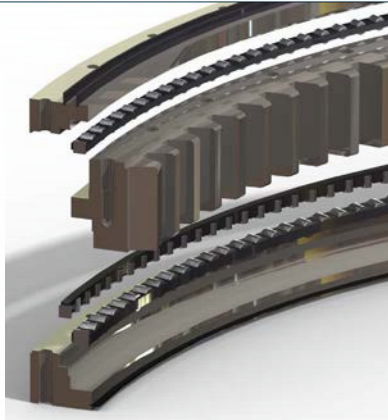

Three row slewing bearing for mining material reclaimer. Bore \varnothing 4200 mm / Rollers with engineering surface coating / special cage / rollers with ultra optimized profile help to accommodate better the load when simultaneously the tilting moment and swining rotation are present.

800M100BH Split Bearings and water cooling housing Continuous Casting Machine Altos Hornos de Mexico (AHMSA) working from 2005

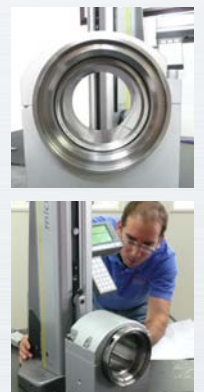
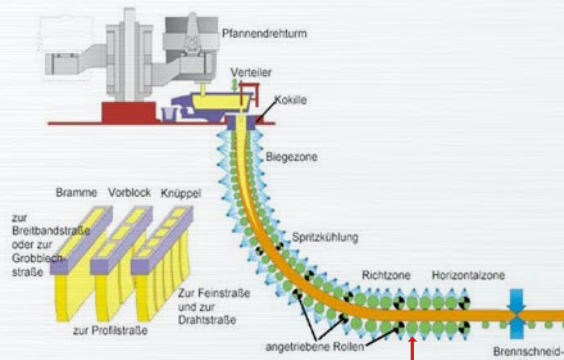

Quality Our state of the art design, manufacturing and quality control process allows us to manufacture customized bearings with one of the highest quality on the market. All key processes, from bearing design through raw material selection, forging, heat treatment, grinding up to assembly operation, are fully controlled and documented. The complete quality control process undergoes a thorough inspection, where 100% of parts are inspected during and after manufacturing process. Additionally we inspect at random in our main QC Lab before final shipment to the customer.

Our engineers use the most advanced software to completely design custom bearings. This process is optimized by including the use of the well known Finite Element analysis (FEM) to meet and exceed each specific application's working condition needs.

A team based relationship is established with the application user in order to obtain the maximum information about the actual bearing working condition. This imperative information is then considered to run a realistic simulation for further analysis.

According to the simulation analysis results, component design may be modified if necessary to obtain the appropriate feature response to guarantee the best component performance in the actual application.

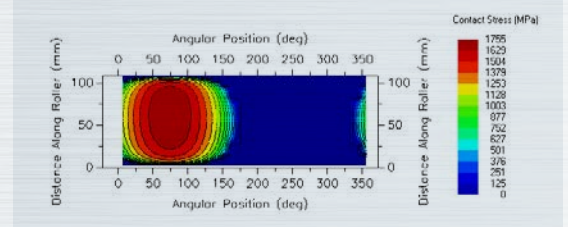
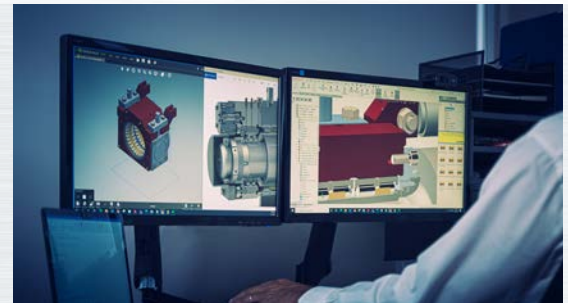

[Inner Contact Stress >](#)

Assembled bearings as well components are submitted to a rigorous quality control process, where the specified manufacturing requirements for every feature is inspected using the ISO 9001:2000 standard as a guide of our quality control protocol.

The most advanced equipment is used during this extensive quality control process. With a precision range from 0.01 to 0.0001 mm they are capable to detect any macro or micro deviation.

Quality control results are analyzed and compared with the application's actual requirements to consider the products as "approved". No single detail is left out in this key process, closing the design and manufacturing cycle followed by an aftermarket support service.

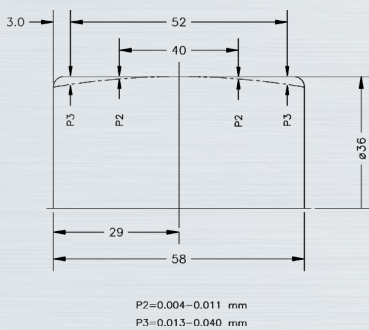

[Roller Actual Raceway Profile](#)

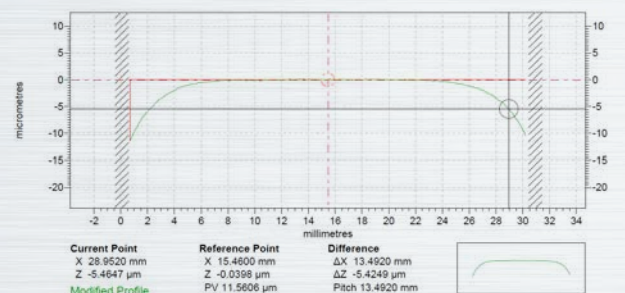

Atlantic Bearing Services 8208 NW 30th Ter Miami, FL 33122 USA
 ph 1.305.592.4404 | sales@atlantic-bearing.com | atlantic-bearing.com

Argentina - Bolivia - Brazil - Canada - Chile - China - Colombia - Costa Rica - Dominican Republic
 Ecuador - El Salvador - Guatemala - Honduras - Italy - Mexico - Nicaragua - Panama - Peru - Spain - USA

↓ Digital Version

