

GIRTH GEARS

For the Heavy Industry

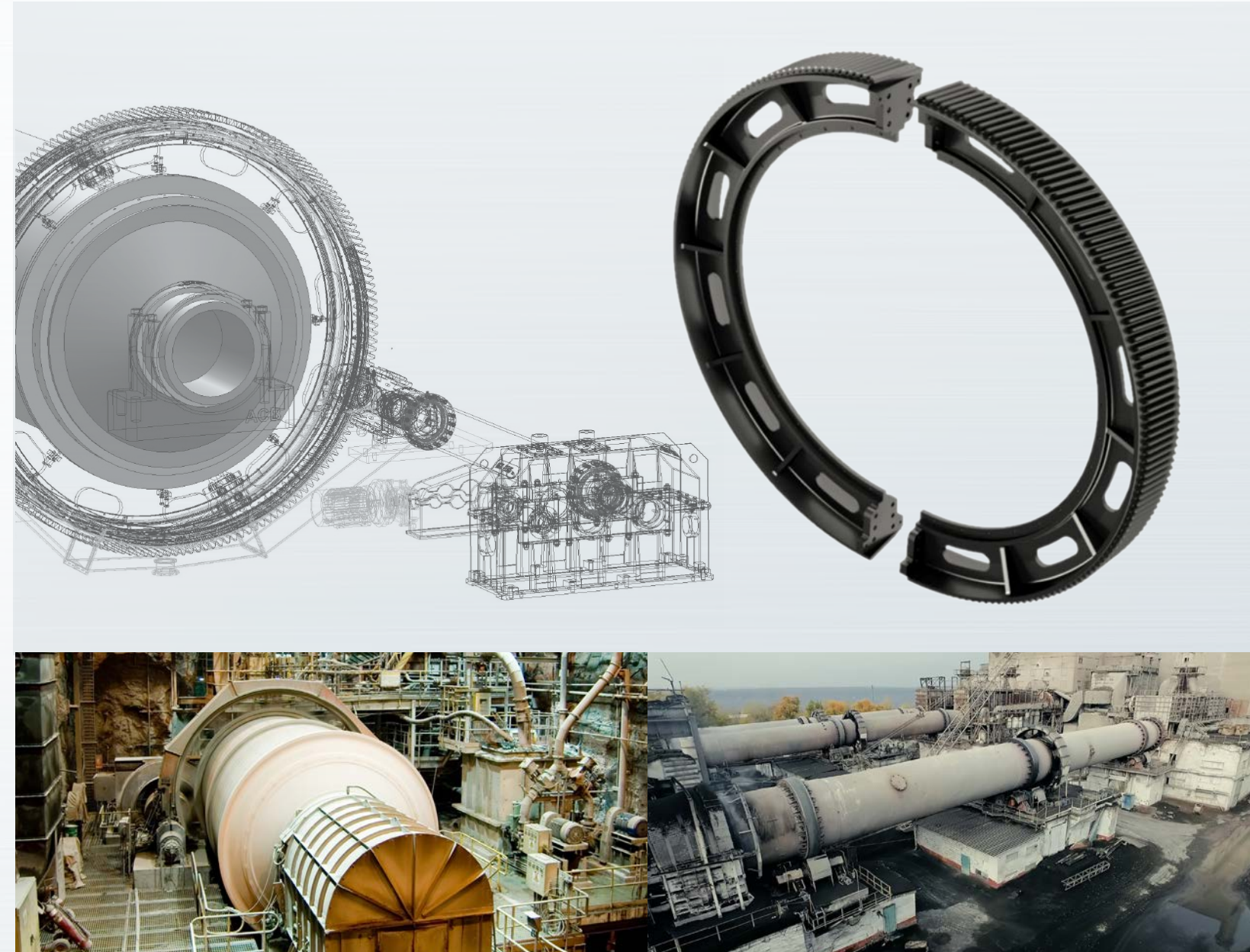
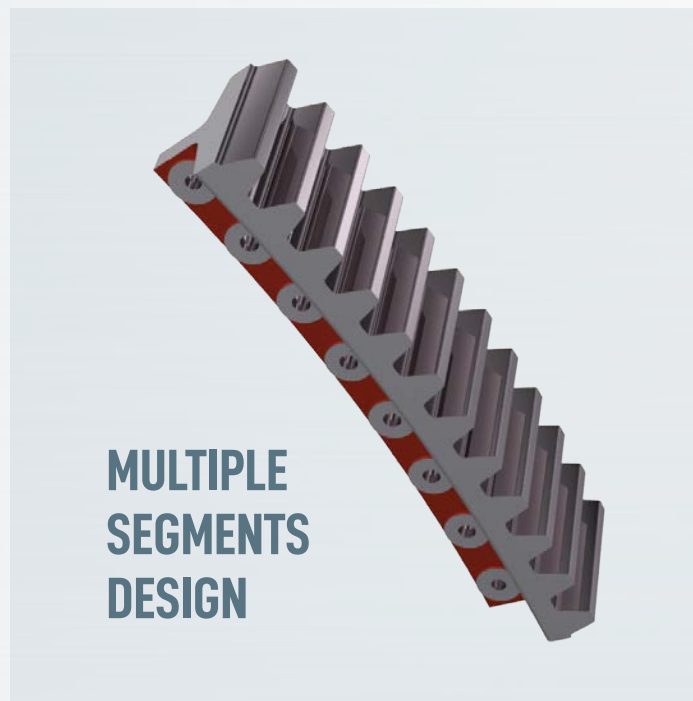

MGS Gears Via Magenta, 77 Int.10 20017 Milan, Italy
ph +39.02.930.2124 | cell +39.33.156.20117 | mgsgears.com

Atlantic Bearing Services 8208 NW 30th Ter Miami, FL 33122 USA
ph 1.305.592.4404 | sales@atlantic-bearing.com | atlantic-bearing.com

Argentina - Bolivia - Brazil - Canada - Chile - China - Colombia - Costa Rica - Dominican Republic
Ecuador - El Salvador - Guatemala - Honduras - Italy - Mexico - Nicaragua - Panama - Peru - Spain - USA

MGS Girth Gears drives for rotate drums, kilns and mills on cement and minerals industry

Argentina - Bolivia - Brazil - Canada - Chile - China - Colombia - Costa Rica - Dominican Republic
Ecuador - El Salvador - Guatemala - Honduras - Italy - Mexico - Nicaragua - Panama - Peru - Spain - USA



Girth gears for high demanding applications

Girth Gears work in several essential industries around the world, including mining, cement, and minerals. Girth Gears, which are usually mounted on the outside of horizontal mills, rotary mills, and kilns, supply the system's principal rotating drive and must therefore be reliable, efficient, and long-lasting.

Girth Gears are utilized in a variety of mining, cement, and minerals processing applications where downtime is not an option, such as copper, gold, silver, platinum, and iron ore production.



Girth Gears Finite Element Analysis

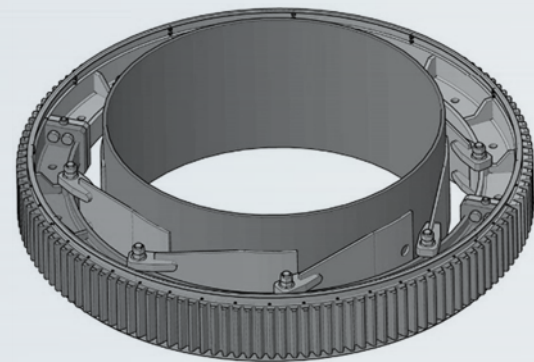
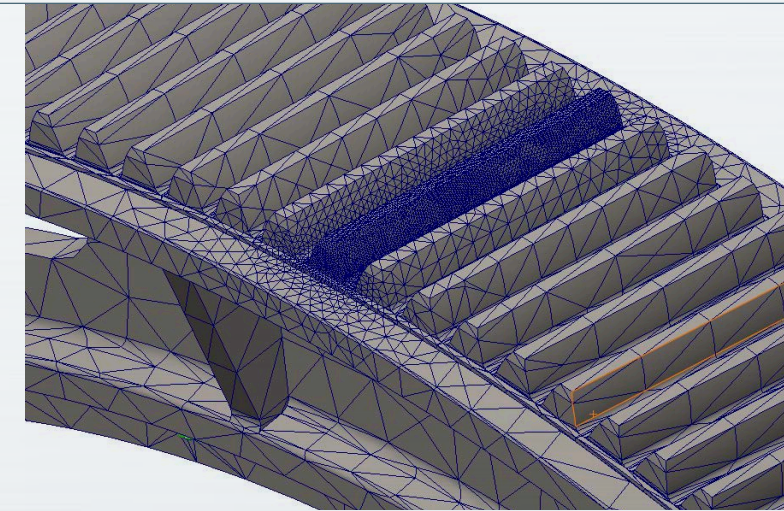
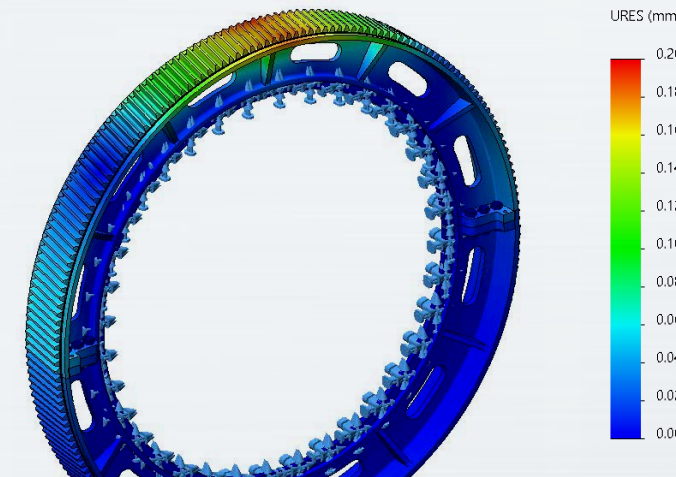

ROBUST AND RELIABLE

High integrity girth gears designed for ultimate strength and reliability

Options for cast steel, SG iron and forged/fabricated gears
320BHN hardness can be achieved with cast gears, 340BHN with fabricated options

Designed and manufactured to major international standards including AGMA

Proven designs supported by a global reference list

3X three year warranty packages available for extra assurance



GLOBAL EXPERTISE DELIVERED LOCALLY

Extensively field tested and proven

Access to a global network of service, installation and operation experts

Global manufacturing capabilities supported by a professional supply chain

Customer focused approach - when you need us, we will be there

Capacity up to 14m diameter

For over 40 years our engineering department has collected data on behavior and performance of the components of dozens of cement mills in the 1000 to 3600 kW range. Vibration readings have been taken on main moving parts and their relevant supporting structures; in addition, the status of analyzed elements and any problem arising have been recorded.

Such readings have been repeatedly taken at preset intervals so as to create a comprehensive data base. Recently, we set up powerful design workstations and installed dedicated software packages for the finite-element method calculation. By using these packages, we can analyze the critical components of machines of our own design as well as other machines.

State of the art manufacturing process

